



This manual is for reference and historical purposes, all rights reserved.

This page is copyright© by M. Butkus, NJ.

This page may not be sold or distributed without the expressed permission of the producer

I have no connection with any camera company

On-line camera manual library

This is the full text and images from the manual. This may take 3 full minutes for the PDF file to download.

If you find this manual useful, how about a donation of \$3 to: M. Butkus, 29 Lake Ave., High Bridge, NJ 08829-1701 and send your e-mail address so I can thank you. Most other places would charge you \$7.50 for a electronic copy or \$18.00 for a hard to read Xerox copy.

This will allow me to continue to buy new manuals and pay their shipping costs.

It'll make you feel better, won't it?

**If you use Pay Pal or wish to use your credit card,
click on the secure site on my main page.**

HASSELBLAD®

553ELX

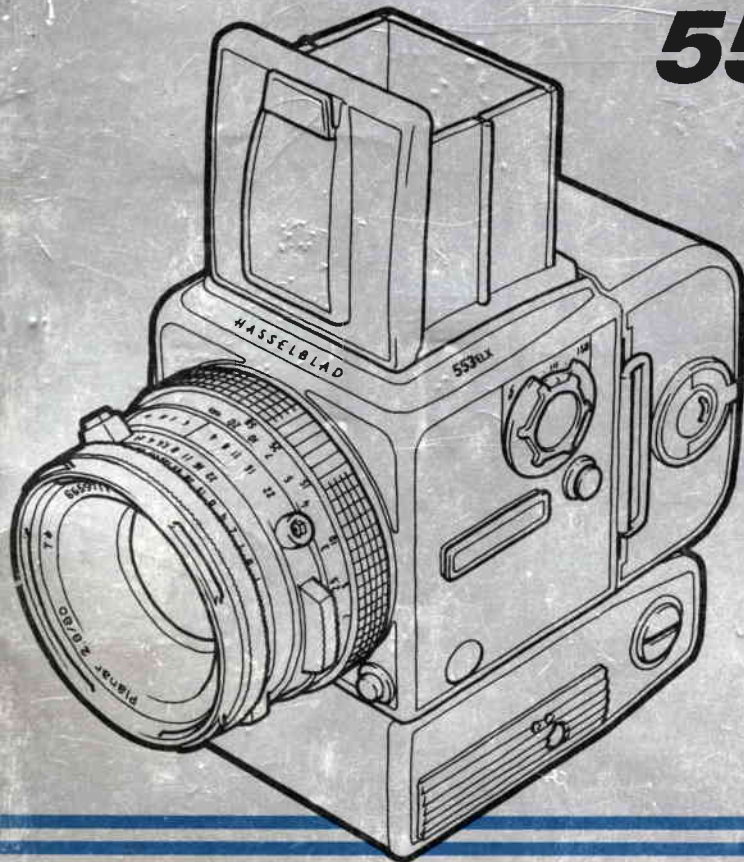

INSTRUCTION MANUAL

Hasselblad 553ELX Instruction Manual

Page

3	Introduction
4	Parts and Components
6	Basic Instructions
6	Batteries and Fuse
8	Normal Settings
8	Front Protective Cover
8	Rear Protective Cover
8	Attaching the Lens
9	Removing the Lens
10	Attaching the Magazine
10	Removing the Magazine
11	Camera and Magazine Indicators
12	Focusing Hood and Magnifier
13	Strap Lugs
13	Left Hand Grip
13	Focus and Release
14	Operating Details
14	Exposure
14	Time Exposure and Locking (LOT) Lever
15	Release Sockets
15	Release Cords
16	Mode Selector Dial
17	Remote Control Socket
17	Double Exposure
18	Battery Types
19	Battery Check
20	Lens and Shutter Functions
20	Shutter speeds
20	Aperture
21	Exposure Values

Page

21	Shutter Speed/Aperture Interlock
22	Focusing and Depth of Field
22	Infrared Photography
23	Checking Depth of Field
23	Flash Synchronization
24	Magazine Operation
24	Loading the Magazine
26	Load Status
26	Removing the Film
26	Film Tab Holder
26	Changing the Magazine Status Indicator
26	Film Plane Index
27	Viewfinder System
27	Changing the Viewfinder
27	Changing the Magnifier
28	Changing the Focusing Screen
28	PME and PME3/PME5 Viewfinder Adjustment
31	Automatic Flash Control
32	Flash Adapters SCA390/590
32	Film Speed Setting
33	Viewfinder Signal
34	Accessories
34	Accessory Mounts
35	Accessory Chart
36	Technical Specification
37	Camera Body Dimensions
38	Troubleshooting
39	Circuit Diagram
40	Camera Care, Service and Guarantee

Copyright © 1992. Victor Hasselblad AB.

All rights reserved. No part of this material may be reproduced, stored in a retrieval system, or transmitted, in any form or by any means, electronic, mechanical, photocopy recording, or otherwise, without the prior written permission of the Company

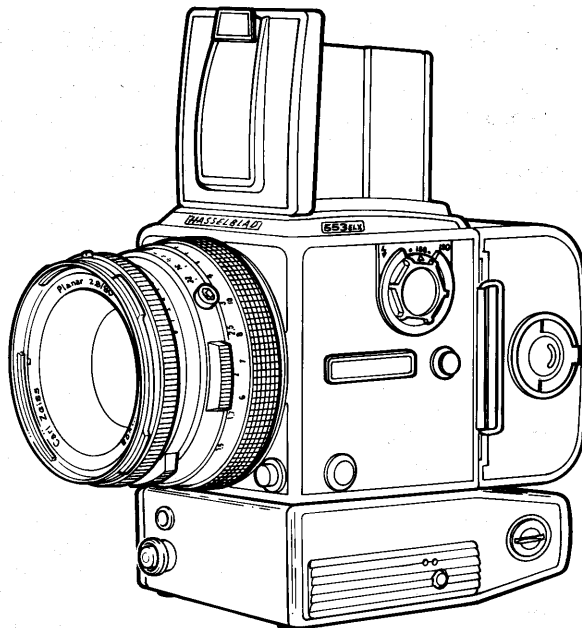

Guarantee

Provided that you bought your camera from an authorized Hasselblad outlet, it is covered by an international guarantee for one year. Further details can be found on page 40.

Service and Maintenance

While Hasselblad equipment is extremely reliable and durable, cameras and lenses that are in constant intensive use in a professional environment should be maintained and serviced by an authorized Hasselblad service center at regular intervals. Further information on service and maintenance can be found on page 40.

Introduction to the Hasselblad Camera System

As a Hasselblad owner, you have in your possession a camera of exceptional quality, the product of an internationally renowned tradition of excellence in the world of photography. Victor Hasselblad, the father of the cameras which bear his name, was himself an accomplished photographer. It was to satisfy his own exacting standards and diverse requirements that he first envisioned the Hasselblad system: a medium format single lens reflex camera with interchangeable lenses and film magazines. A photographer first and businessman second, Victor Hasselblad would never sacrifice quality for ease of production. To this day, Hasselblad cameras are painstakingly crafted with this principle in mind.

The Hasselblad system has been taken to the ends of the earth and beyond – into space, to earn its reputation for reliability and absolute fidelity. A range of accessories affords limitless flexibility and the potential for successful photography in any application. The realisation of this potential is of course dependant upon the skill, care and judgement of the photographer.

The Hasselblad 553ELX is a motorized single lens reflex camera featuring lens, magazine,

viewfinder, and focusing screen interchangeability. It is capable of TTL/OTF ('Through The Lens/Off The Film') flash metering, providing direct full control of the Hasselblad Prof flash 4504 flash unit or, with Hasselblad flash adapters SCA 390 and 590, of the Hasselblad Macro Flash unit or any flash unit conforming to the European Systems SCA 300 and 500. When the flash output is sufficient to provide a correct exposure the flash units' discharge is automatically cut off. TTL/OTF metering is particularly important when using electronic flash for macro photography.

Lenses

Since the early 1950's the Hasselblad lenses have been manufactured by Carl Zeiss in Germany. All C and CF lenses manufactured after 1957 can be used with the 553ELX. F-type lenses, however, can only be used with Hasselblad focal plane shutter cameras manufactured after 1976.

Use this manual to learn how to operate your camera. The knowledge gained from reading it will give you access to the Hasselblad potential. Exploiting the potential is left to your imagination!

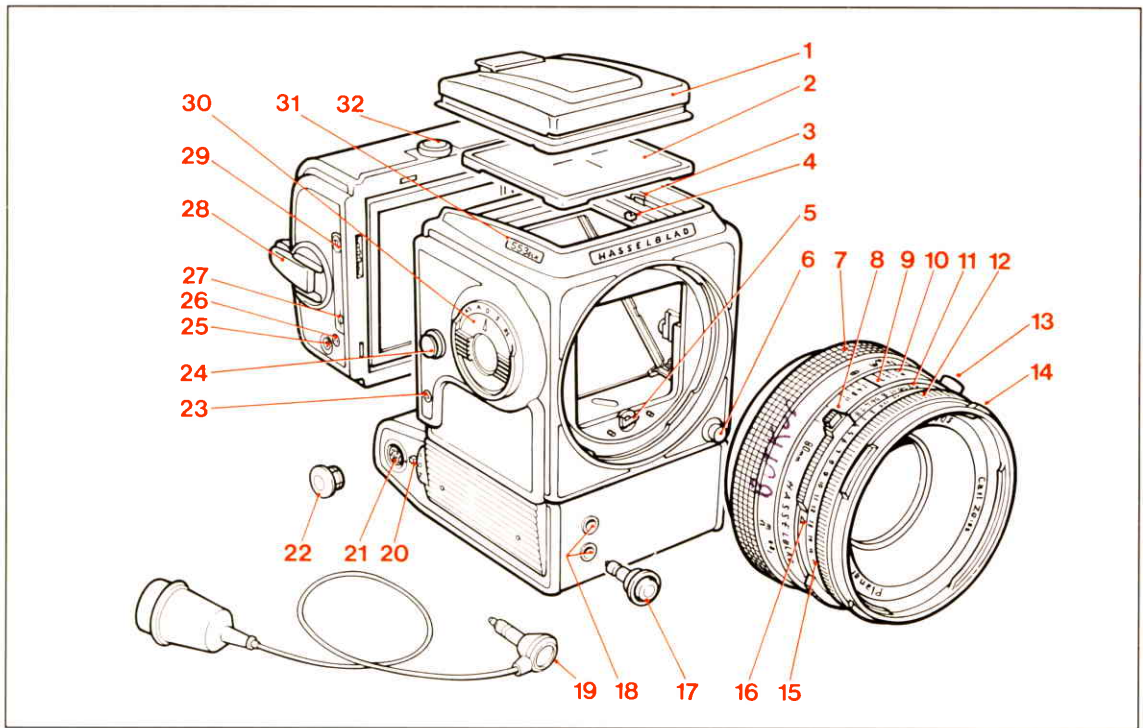

553ELX Parts and Components

- | | | |
|--------------------------------------------------|--------------------------------------------------|------------------------------|
| 1 Focusing hood | 12 Shutter speed ring and scale | 22 Remote socket cover |
| 2 Acute-Matte* focusing screen | 13 PC flash terminal | 23 Camera status indicator |
| 3 Screen retaining clip | 14 External and internal lens
accessory mount | 24 Strap lug |
| 4 Flash function indicator | 15 Exposure value scale | 25 Frame counter |
| 5 Drive shaft | 16 Exposure value index | 26 Magazine status indicator |
| 6 Lens release button | 17 Release button | 27 Film plane index |
| 7 Focusing ring and scale | 18 Front release sockets | 28 Film winding crank |
| 8 Shutter speed and aperture
interlock button | 19 FK30 release cord | 29 Magazine designation |
| 9 Lens central index | 20 Time exposure and locking
lever | 30 Mode selector |
| 10 Depth-of-field scale | 21 Remote release socket | 31 Name plate |
| 11 Aperture ring and scale | | 32 Magazine catch button |

*Acute-Matte designed by MINOLTA

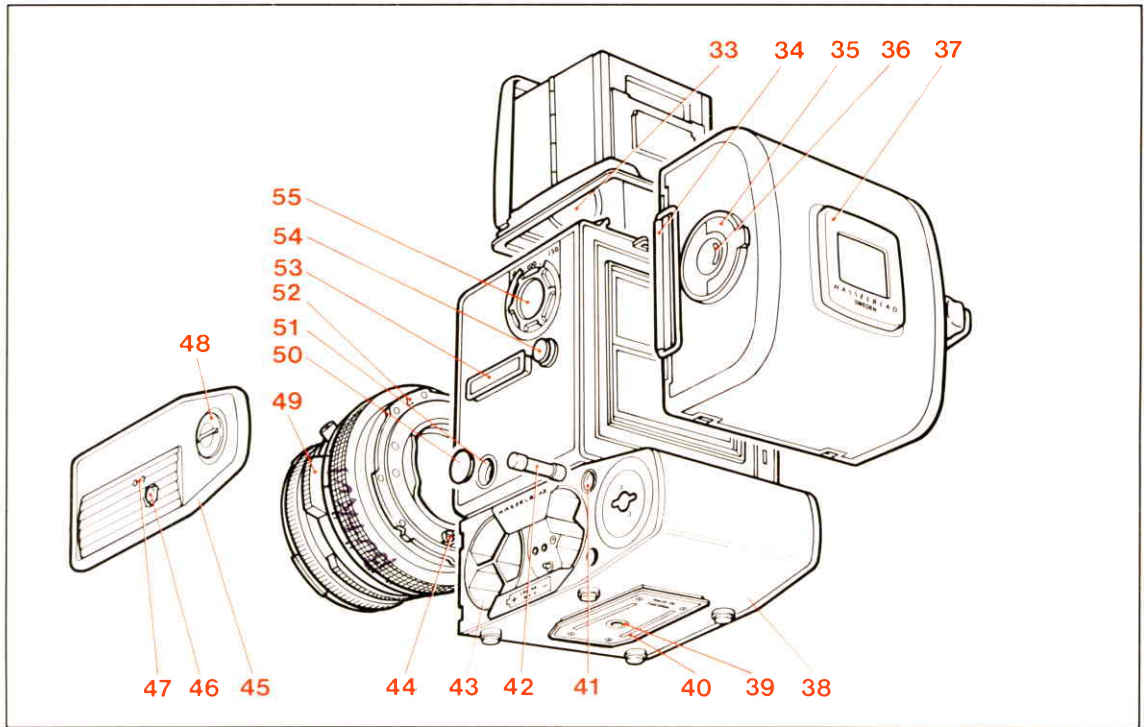

- | | | |
|------------------------------|------------------------------|----------------------------------|
| 33 Focusing hood magnifier | 41 Fuse holder | 49 Depth-of-field preview button |
| 34 Magazine slide | 42 Fuse | 50 Flash connector cover |
| 35 Film holder key | 43 Battery compartment | 51 Dedicated flash connector |
| 36 Film load indicator | 44 Lens drive coupling | 52 Lens locating index |
| 37 Film tab holder | 45 Battery compartment cover | 53 Accessory rail |
| 38 Motor housing | 46 Battery check button | 54 Strap lug |
| 39 Tripod socket 1/4" thread | 47 Battery check lights | 55 Film speed selector |
| 40 Quick-coupling plate | 48 Cover locking button | |

NOTE: In the text, the positions of components are described in relation to the camera as you see it when taking a photograph, i.e. the lens is on the front, the viewfinder is in the top, and the winding crank is on the right hand side.

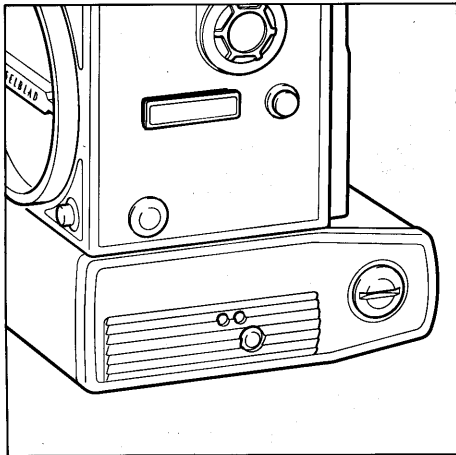

Basic Operation

This section describes the steps you must take to make the camera ready to use. Follow the steps as they are described. **DO NOT ATTEMPT TO ATTACH THE LENS TO A CAMERA WITHOUT BATTERIES.** You will find comprehensive information on how to operate the camera in the following sections.

Batteries and Fuse

You cannot operate the camera until you have inserted the batteries and the fuse into the battery compartment. To get access to the battery compartment you have to remove the cover on the left hand side of the motor housing, i.e. the lower section of the camera body. You unlock the cover by inserting a suitable coin into the cover locking button slot and turning it counter-clockwise into a vertical position. Now you can remove the cover by opening the rear end outwards and disengaging the hooks in the front end.

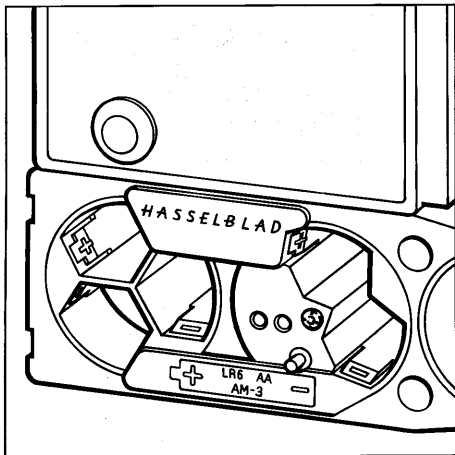

The Battery Compartment

When you have removed the cover the battery compartment will be exposed. If you look closely at the battery receptacles, you will see that there is a symbol moulded inside each one, indicating which way each battery should be inserted. On the front face of the compartment at the bottom is another moulding that represents a battery, showing the positive and negative ends and the various different designations of the required battery type.

The Batteries

You will need five 1.5V alkaline batteries size AA (alternative designations are LR6 or AM-3). Fresh batteries will give you up to 4000 exposures at ambient temperatures above 32°F (0°C).

Regarding use of other battery types, see page 18, **Battery Types**).

The Fuse

The fuse is a 5 x 20mm instrument fuse rated 1.6A medium slow-blow (semi time-lag).

Fitting the Batteries

Fit the batteries into the compartment in accordance with the symbols moulded into the receptacles. Once fitted the positive (+) ends of the two uppermost batteries and the negative (-) ends of the other three, should be visible. Fit the fuse into its receptacle at the top right hand side of the battery compartment. It is always advisable to have a spare fuse, which can conveniently be carried in the hole directly below the fuse receptacle.

When you refit the cover you must ensure that the two hooks in the front of the cover positively engage in the corresponding slots in the front of the motor housing. Firmly holding the hooks in place you insert the coin in the lock button slot. Keeping the slot strictly vertical you push the cover against the resistance of the contact springs until the lock pin engages in the slot in the motor housing. While pushing you turn the lock button clockwise until it stops (approximately 1/4 turn) and the cover will be locked in place.

NOTE: If the camera has been released using the lock/time (LOT) lever without batteries inserted, the mechanism remains in the released state. When the cover is positioned after batteries have been inserted the power circuit is closed and the camera will start and complete the rewind cycle.

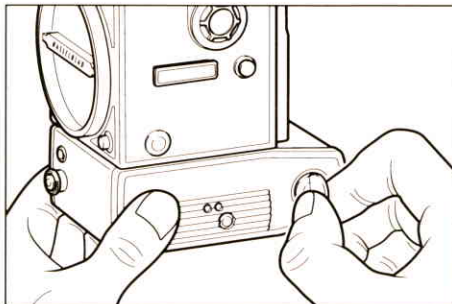
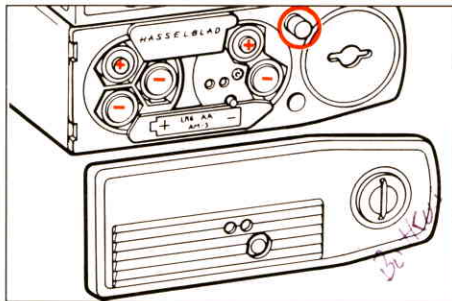

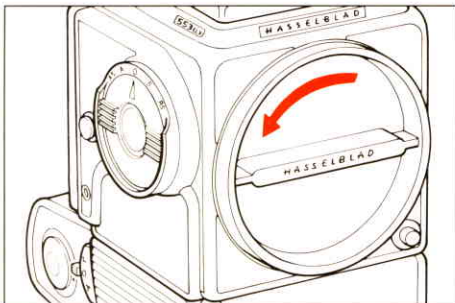

Normal Settings

While setting up the camera as described in this section, it is important that both the mode selector dial and the 'LOT' lever are set in the 'O' position. You will find detailed information about these items on pages 14 and 16.

Front Protective Cover

Turn the cover (bayonet fitting) in the direction of the arrow and remove.

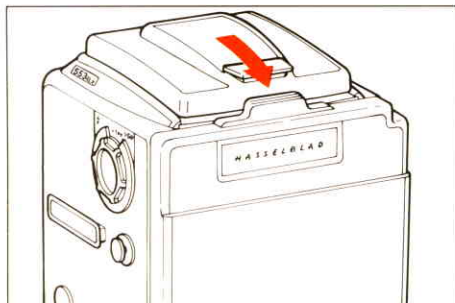

Rear Protective Cover

Depress the catch, tilt the cover backwards, and lift it off.

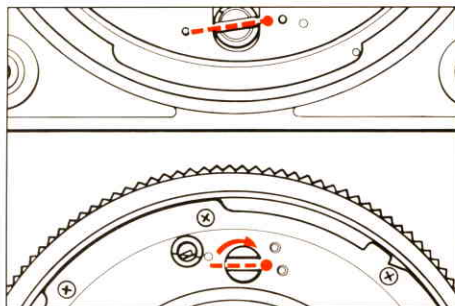

Attaching the Lens

DO NOT ATTEMPT TO ATTACH THE LENS TO A CAMERA WITHOUT BATTERIES!

Make sure that both camera and lens are fully cocked. The adjacent illustration shows the correct relationship between the drive shaft, the lens drive coupling and their indexes.

If the camera is not fully cocked (it may have been accidentally pre-released), press and re-lease the release plate. The camera will then wind on and be fully cocked.

If the lens is not cocked, you can insert a coin in the coupling slot and rotate it clockwise until it locks (about 4/5 of a turn).

You will find that holding the camera in your left hand and the lens in your right hand, as shown in the illustration, is the easiest way of attaching the lens.

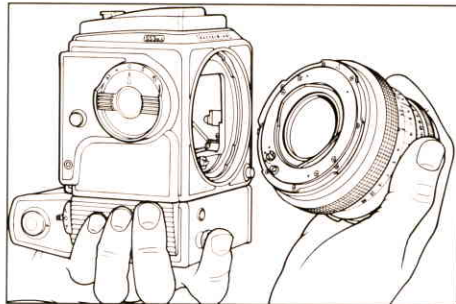

When you have aligned the orange index on the lens with the one on the camera as shown in the illustration, the lens will be correctly positioned into the bayonet fitting. You can then rotate it clockwise until it stops with a faint click as the lens catch locks it in place.

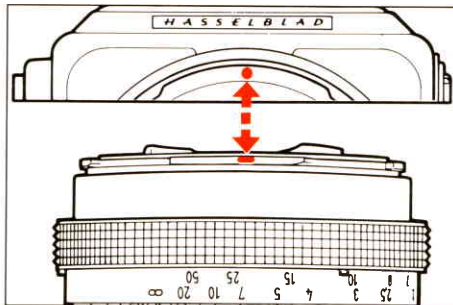

Removing the Lens

Depress the lens release button and rotate the lens counter-clockwise until it stops.

NOTE: You can only remove the lens when the camera is cocked (fully wound) and not in the pre-released mode (see page 16).

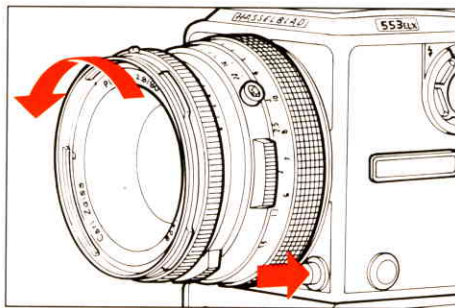

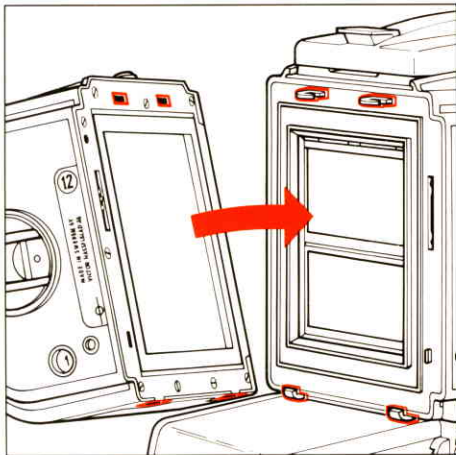

Attaching the Magazine

Ensure that the magazine slide is fully inserted, and that the indicators are white. If the indicators are not white, then refer to the instruction on page 11.

Rest the magazine on the camera's magazine supports and make sure that it is properly located on them. Carefully swing the magazine towards the camera body and check that the camera's magazine hooks fit into the slots in the magazine.

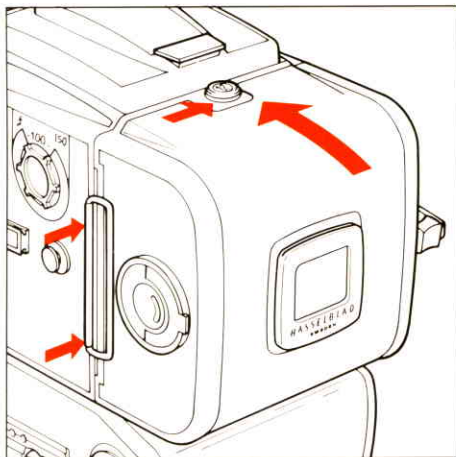

Push the magazine gently but firmly against the hooks while sliding the magazine catch button to the right.

Release the button when the magazine has made contact with the rear plate of the camera, and push it to the left to ensure that it has reached the locked position. Remove the magazine slide and the camera is ready to use.

Removing the Magazine

It is advisable to have the camera cocked (fully wound) and the magazine indicator displaying white. If the magazine indicator shows a red signal then follow the instructions on page 11.

Insert the magazine slide into the magazine with the hinge towards the front of the camera.

Slide the magazine catch to the right, swing the magazine back and lift it off the magazine supports.

NOTE: The magazine cannot be removed without inserting the magazine slide. The slide protects the film from being inadvertently ruined by exposure. Note also that the camera cannot be operated when a magazine, with slide inserted, is attached to the camera.

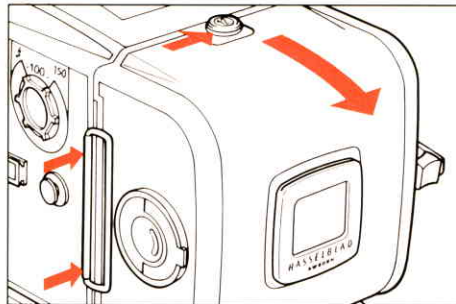

Camera and Magazine Indicators

The 553ELX camera indicator is permanently set on white. The magazine indicator shows whether the film has been advanced (white) or not (red). When the magazine is attached to a camera body, it can also be used to determine whether the camera has been released but not wound on (red) or is ready to be operated (white). The exception is when the magazine has been removed to produce a double exposure, see page 17. If the magazine indicator shows red, the film has to be advanced to change the indicator to white. This can be carried out in two different ways. The procedure below has to be used on frame No. 1 and can be used on all consecutive frames.

1. Set the 'LOT' lever from the O (normal position), to the T (time exposure) position.
2. Attach the magazine to the camera, leaving the magazine slide in place.

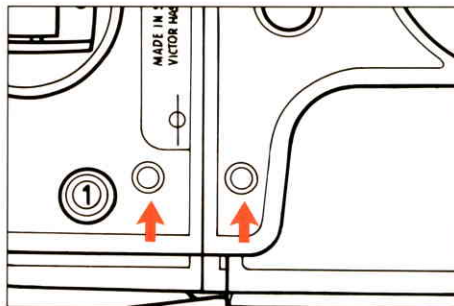

3. Return the lever to the O position. The camera will now start to wind the film on and the magazine status indicator will change to white.

A simpler method to advance the film on all frames except frame No. 1 is described on page 26.

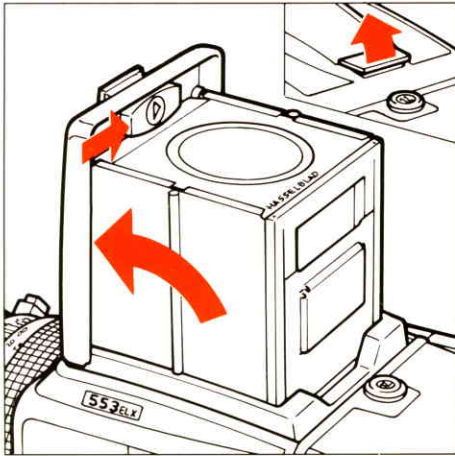

Opening the Focusing Hood

Open the lid by gripping the tab firmly and lifting it to the vertical position.

The Built-in Magnifier

The magnifier flips up into the viewing position when the oval button inside the lid is moved in the direction of the arrow.

To fold the magnifier down simply press it back with your fingertip until it locks into the lid.

The magnifier may be exchanged for correction lenses. See page 27.

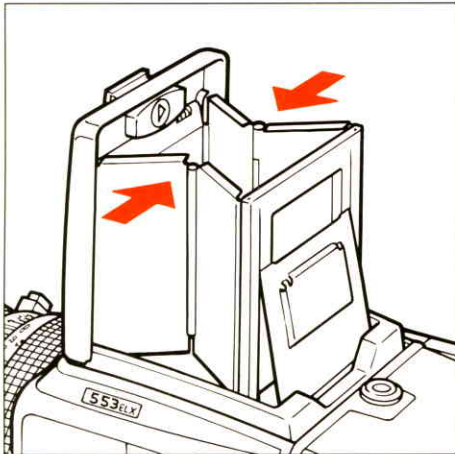

Closing the Focusing Hood

“Pinch” in the side plates at the hinge points, and fold the lid down.

Strap Lugs

Strap Attachment

Place the main body of the strap clip over one of the camera's strap lugs. Press down on the tip of the clip and pull back, and ensure that the locking plate secures the strap in place.

Strap Removal

Lift the clip locking plate and slide the clip forward. The strap is then freed from the camera.

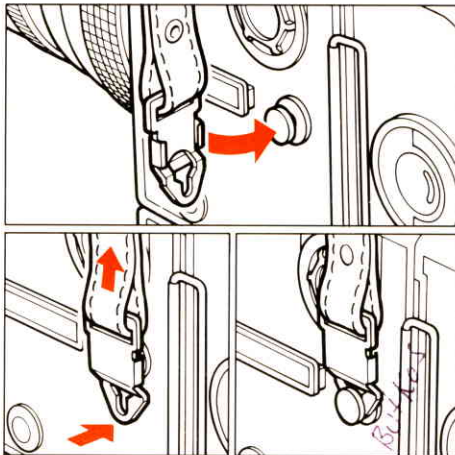

Left Hand Grip

You will find that holding the camera in your left hand with your index finger on the release plate, as shown in the illustration, is most convenient when taking photographs. Your right hand is then free for focusing, setting the exposure and changing the lens or magazine.

Focus and Release

Before you can take a photograph, you must remove the magazine slide. The magazine will then be locked on the camera body, and the camera release plate will be operative.

Rotate the focusing ring on the lens until you can see a sharp image of the subject in the viewfinder. You can now depress and release the release plate to operate the camera.

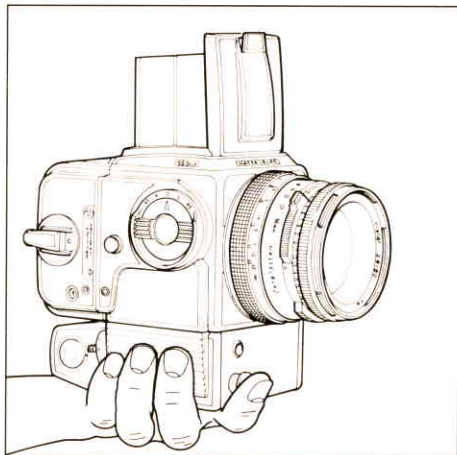

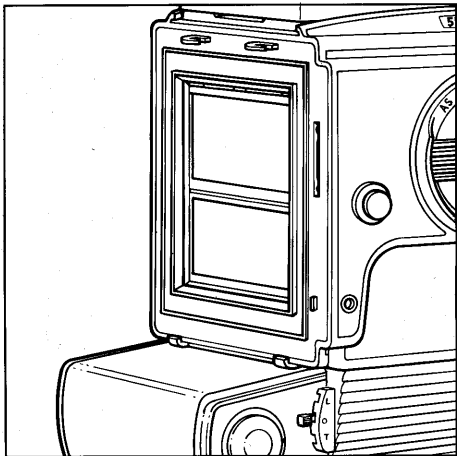

Operating Details

Exposure

As a general rule for all shutter speed settings except B, with the 'LOT' lever in the O position you should keep the release plate depressed until the lens shutter has completed the exposure. This is especially important at shutter speeds from 1s to 1/15s.

If you relax the pressure on the release plate too soon, the auxiliary shutters will terminate the exposure prematurely (see page 20, 'Warning Signal'). The auxiliary shutter consists of two blinds covering the rear opening of the body.

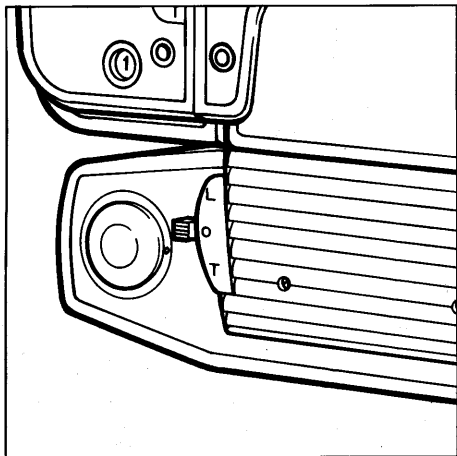

Time Exposure and Locking ('LOT') Lever

The lever located toward the rear of the motor housing allows you to select time exposure (T), locking (L), or normal operation (O).

(O) – Normal operating position.

(T) – For time exposures, you should set the lens at B and the mode selector at O, S, or RS. The camera shutter is mechanically opened when the 'LOT' lever is shifted from O to T. The shutter then remains open without any drain on the battery. When the lever is returned to the O setting the shutter closes, the film is advanced, and the shutter is cocked automatically.

(L) – In the L-mode, release is blocked to prevent inadvertent exposures.

Release sockets

Hasselblad 553ELX has two release sockets at the front of the motor housing. The sockets are parallel connected and can be used optionally for inserting the release button.

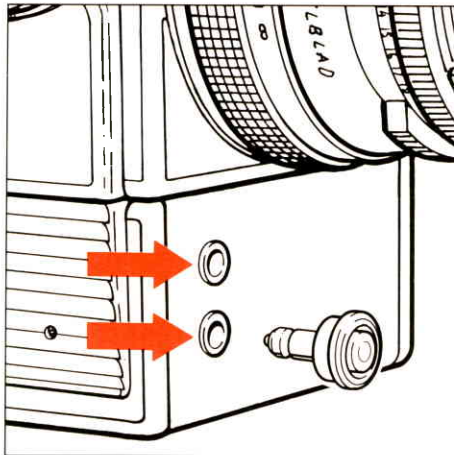

Release Cords

A tripod should be used when operating the camera at slow shutter speeds. A release cord provides a suitable means of releasing the camera. FK type release cords 0.3 and 6 metres (1 and 20 feet) long can be connected to either of the front sockets. LK and SK type release cords between 1.5 and 5 metres (5 and 16 feet) long must be connected to the remote control socket.

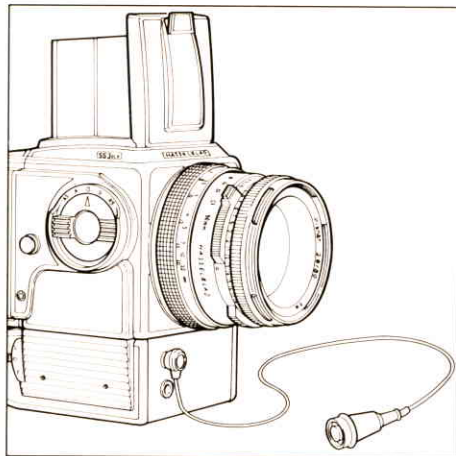

Mode Selector Dial

The selector dial offers five release modes for the camera.

O – NORMAL MODE. Exposure occurs when the release plate is depressed. The film is advanced,

the shutter cocked and the mirror returned to viewing position when the pressure on the release plate is removed.

S – PRE-RELEASE. When the dial is moved to this position the lens shutter is closed, the diaphragm stops down to the pre-selected aperture, the mirror swings up and the auxiliary shutter opens. Only the actual operation of the shutter remains when the release plate is pressed. Since most of the camera operations are pre-released, the camera's reaction time between release and exposure is reduced to a minimum, as is camera induced vibration. The selector dial is not retained in the S-position but returns to the O-position when released.

RS – The camera is pre-released when the mode selector is moved to RS where it is held, and continues to pre-release after each exposure until the mode selector is returned manually to the O or A position.

A – Automatic. The camera makes a continuous sequence of exposures as long as the triggering impulse is applied, and unexposed film remains in the camera. The sequential exposure rate in this mode is about 1 frame/sec.

AS – The camera is pre-released in AS and exposes sequentially as long as the exposure button is kept depressed. At the end of the sequence the camera remains in a pre-released state. The exposure rate is slightly faster than in the A position.

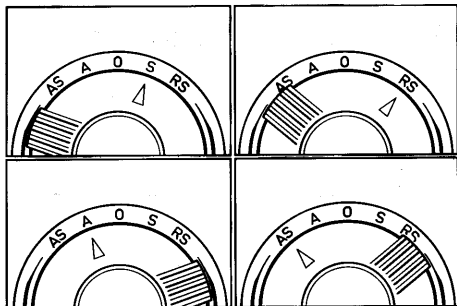
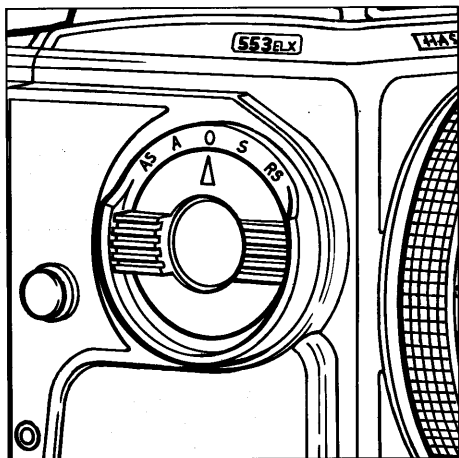

Remote Control Socket

At the rear of the motor housing on the right hand side is a 5-pole DIN-socket. You can use this to operate the camera by means of the release cords (SK and LK), a timer or any means that closes the circuit between pins 1 and 3 (see page 38, Circuit Diagram). The external resistance should not exceed 6 ohms and the circuit should remain closed at least 0.1sec for reliable triggering.

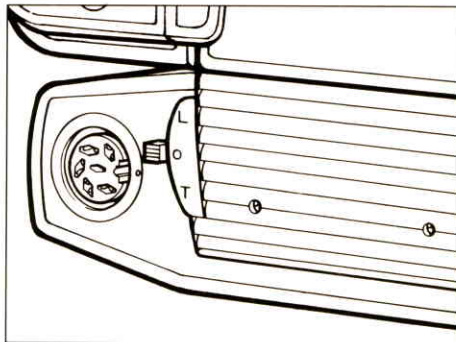

Double Exposure

The camera has been designed to prevent accidental double exposure. Intentional double and multiple exposures on the same frame can be carried out as follows:

1. Depress the release plate and keep it depressed. The magazine status indicator now shifts to red.
2. Move the LOT lever to the L position and relax the pressure on the release plate.
3. Insert the magazine slide and remove the magazine from the camera.
4. Return the lever to the O position. The camera will wind on.
5. Replace the magazine and remove the slide.

The unit is now ready to make a second exposure on the same frame even though the magazine indicator is red. You can make additional exposures in the same manner.

The magazine status indicator remains red until the magazine is left on the camera and wound on.

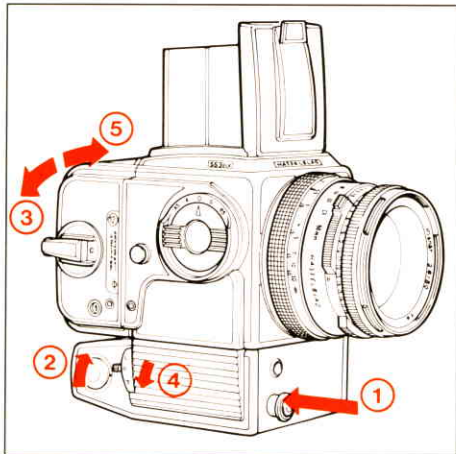

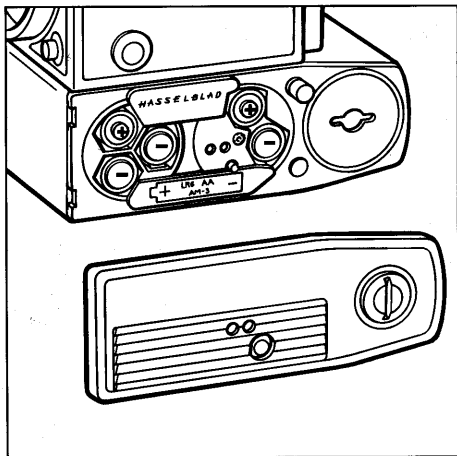

Battery Types

The five AA size batteries used can either be non-rechargeable alkaline (LR-6, AM-3) or rechargeable nickel-cadmium (NiCd) types, but must all be of the same type and in similar condition. Fresh alkaline batteries will last for at least 4000 exposures at ambient temperatures above freezing. Rechargeable NiCd batteries have less than half this capacity when fully charged. Common zinc-carbon batteries can be used but have a considerably shorter life span and should be avoided because they may leak and cause serious damage to the interior of the camera. Lithium type batteries cannot be used due to their higher voltage. Rechargeable batteries can be recharged in a standard Recharge Unit for AA size batteries.

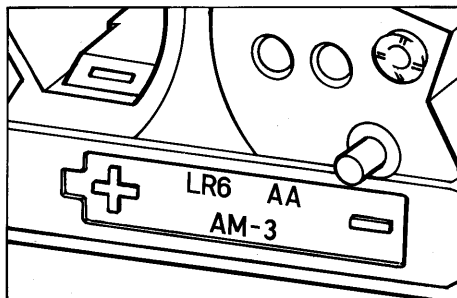

The batteries must always be removed when the camera is not in use for long periods.

Please note that for environmental reasons alkaline batteries should not be disposed of with ordinary rubbish.

Checking the Batteries

When you depress the battery check button the green lights indicate the remaining battery power. The following indications are valid for alkaline batteries.

- Two lights: More than 40% remaining power
- One light: Less than 40% but more than 20% remaining power.
- No lights: Less than 20%. Change to fresh batteries!

The battery check circuitry cuts off the lights after 1 - 1.5 sec. in order to conserve battery power.

Rechargeable batteries cannot be checked in this way since alkaline batteries and rechargeable batteries have different discharge characteristics.

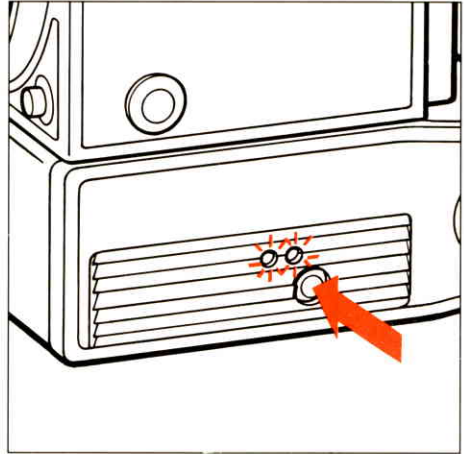

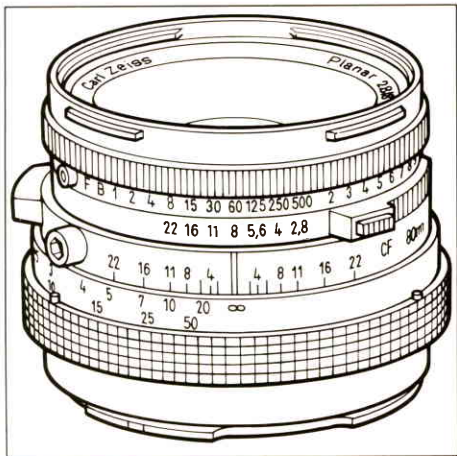

Lens and Shutter Functions

Shutter Speeds

The shutter speed ring is located closest to the front of the lens. The desired shutter speed is set against the lens index.

The white scale shows the shutter speeds, and the orange scale the exposure values (EV).

The green F setting is used only when the lens is attached to a Hasselblad focal plane shutter camera of the 2000 series. The operation of the diaphragm is not affected. The F setting can only be engaged/disengaged when the green detent button is pressed. When using the 553ELX, the F setting will cause exposure errors since the shutter remains open.

Aperture

The aperture ring is second closest to the front of the lens. The aperture value is also set against the lens index.

CF lenses have an automatic diaphragm that stops down to the preset working aperture immediately prior to exposure.

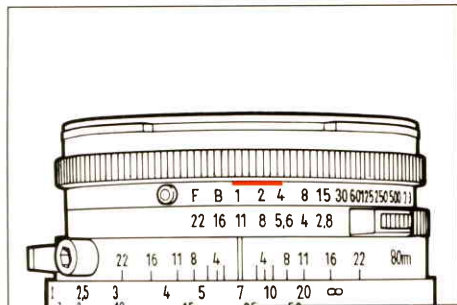

Warning Signal

The shutter speed ring has an orange marking opposite the 1, 1/2, and 1/4 s. This is to remind you to maintain pressure on the release button until the lens shutter has completed the exposure (see also page 14, **Exposure**). With the 553ELX you should extend this recommendation to include also 1/8 and 1/15 s due to the fast reaction of the camera's motorized rewind operation.

Exposure Values

The aperture and shutter speed combination set opposite the lens index determines the exposure. Every combination of shutter speed/aperture has an equivalent exposure value (EV). This you can read and set against the orange EV index on the side of the lens key.

Note: Hasselblad PME and PME-3 Meter Prism Viewfinders give direct EV readings.

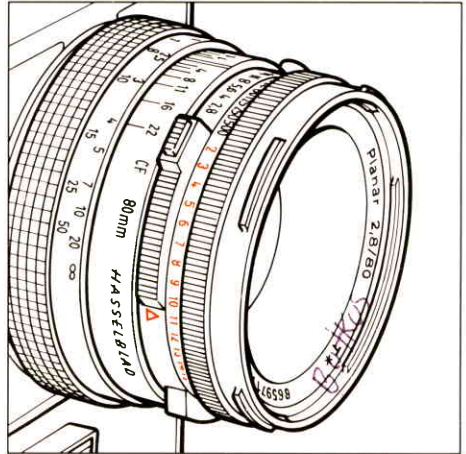

Interlocked Shutter Speed/ Aperture

If you want to change the shutter speed or aperture without changing the EV, you can interlock the speed and aperture rings by holding down the interlock button on the right of the aperture scale then turning the interlocked rings to the desired aperture and speed combination that will produce the image required. When interlocked, the rings move together, increasing or decreasing the aperture and shutter speed to maintain the EV for correct exposures.

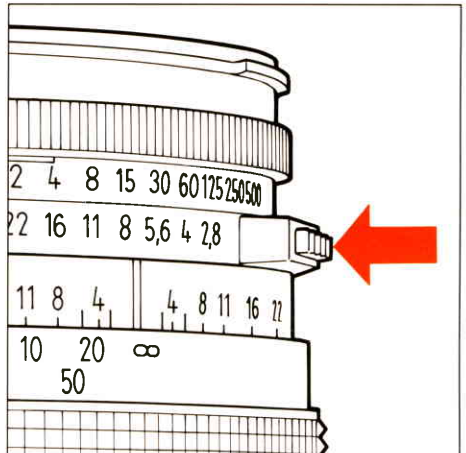

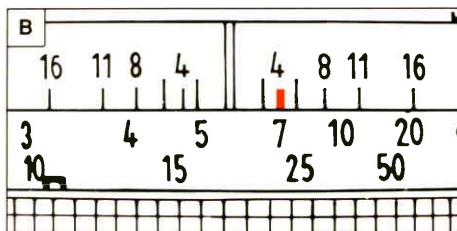
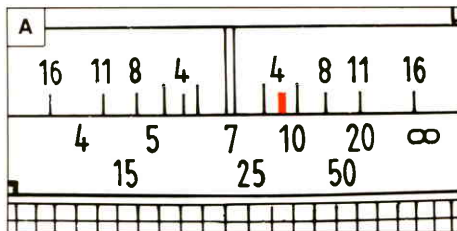
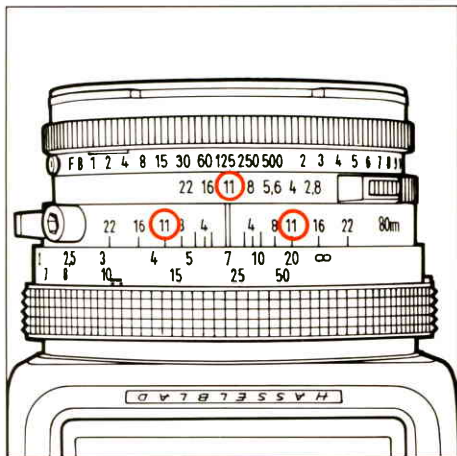

Focusing and Depth of Field

The focusing ring is the ring with the knurled rubber grip positioned closest to the camera body. The distance scales appear on this ring. You focus the lens by rotating the focusing ring until a sharp image of the subject is obtained or the measured distance between the subject and the film plane is set opposite the lens index. The distance in metres is shown in white numerals, and the distance in inches/feet is in orange numerals.

In the image, objects closer or further away than the selected distance will appear sharp, within certain limits. The range of sharp focus, i.e. depth of field, varies with the aperture.

The depth of field available at any given aperture can be read off the depth-of-field scale on both sides of the central index. The rings on the illustration indicate how to read the depth-of-field scale with an aperture of $f/11$.

Infrared Photography

Infrared (IR) rays (wavelengths longer than 800 nanometers) are refracted to a focal plane somewhat behind that of the visible light images formed on the focusing screen. To compensate for this difference, proceed as follows:

Focus as usual on the focusing screen (see figure A).

Read the distance opposite the central index.

Rotate the focusing ring until the distance read is aligned with the red IR index (see figure B).

Checking Depth of Field

To allow you to see the depth of field in the image on the focusing screen as it will appear on the film, the diaphragm can be stopped down to the preset aperture simply by sliding the manual preview button downwards until it locks into the preset position. The diaphragm will remain in this position until it is manually opened.

To release the button, and re-open the diaphragm, press the lower section of the button.

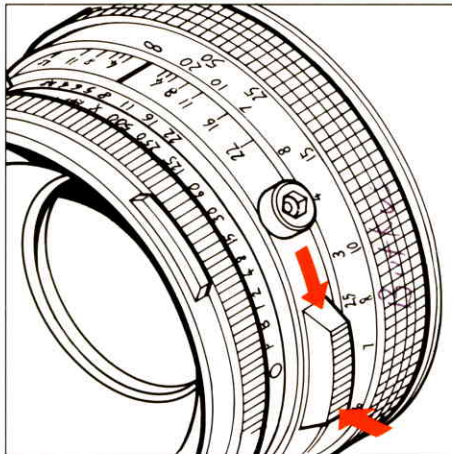

Flash Synchronization

The Hasselblad 553ELX uses lenses from the Hasselblad CF and C series. These lenses have built-in leaf shutters with speeds from 1 to 1/500s. A flash unit connected to the PC terminal will be activated when the shutter is fully open.

Electronic flash units can be used at all shutter speeds, 1 - 1/500.

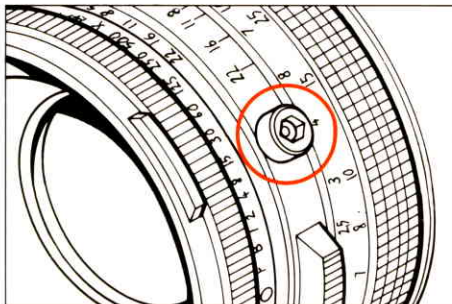

Magazine Operation

Loading the Magazine

The magazine may be loaded on, or off the camera. If it is to be loaded off the camera then the magazine slide must be inserted, its flat side towards the rear. This facilitates removal of the film holder for loading. Follow the procedure below.

- 1) Fold out the magazine insert key.
- 2) Turn the key **counter-clockwise** and withdraw the film holder.
- 3) An empty take-up spool should be placed under the knurled knob of the spool clamp bar. Insert a roll of film under the other end of the bar, ensuring that it is turned the same way as in the illustration. Be careful to remove **all** the paper tape that surrounds a new roll of film.
- 4) Turn the magazine insert key **clockwise** to open the film clamp. Pull 8 - 10cm (3 - 4 in.) of paper backing off the film roll and slide the edge under the clamp.
- 5) Insert the tongue of the backing paper into the slot in the take-up spool.
- 6) Turn the knurled knob **clockwise** until the arrow on the paper backing is opposite the triangular index on the spool clamp bar, but no further.
- 7) Turn the magazine insert key **counter-clockwise** and insert the film holder into the magazine – ensure that it is correctly positioned. Lock the film holder into the magazine by turning the key **clockwise**.
- 8) Fold out the film crank and rotate it **clockwise** about ten turns until it stops. Turn the crank counter-clockwise and fold it in.

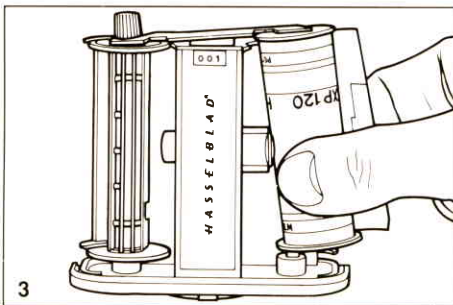
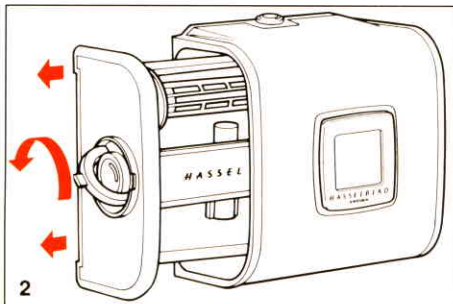
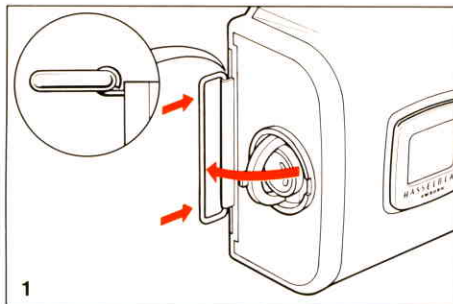

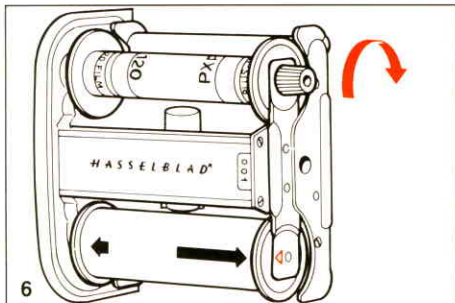
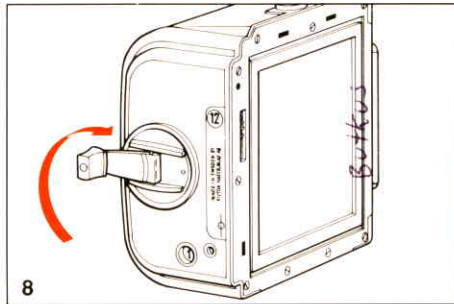
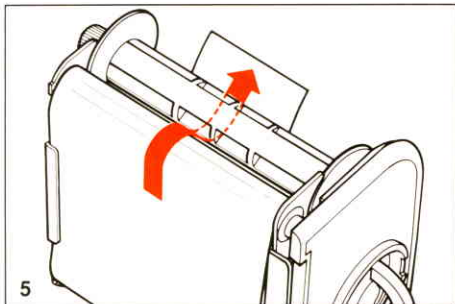
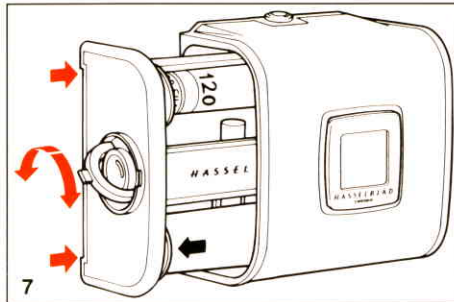
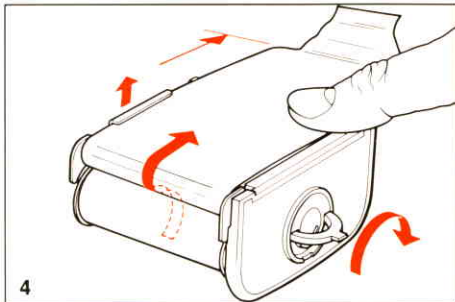

Number 1 will now be displayed in the frame counter window and the magazine is loaded – ready for use.

The magazine's film winder crank is only blocked at frame 1. A partially exposed film may be wound off at any frame thereafter.

The frame counter is automatically reset when the film holder is withdrawn from the magazine.

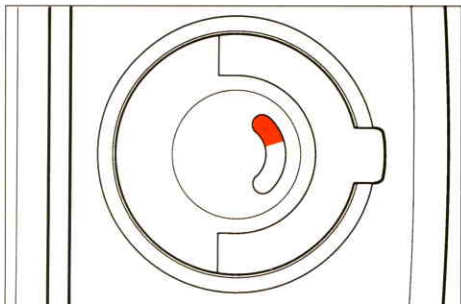

Magazine Load status

In the centre of the film holder key is a crescent-shaped indicator that displays white when the film is loaded into the magazine, and progressively changes to red as the film is wound on. A completely red indicator shows that either the final frame is exposed or the magazine is empty.

Removing the Film

When the last frame has been exposed, the magazine blocks the camera for further exposures. Wind off the film by folding out the film winding crank, and rotating it clockwise until you can feel the film leaving the supply spool. Now you can withdraw the film holder from the magazine and remove the exposed film.

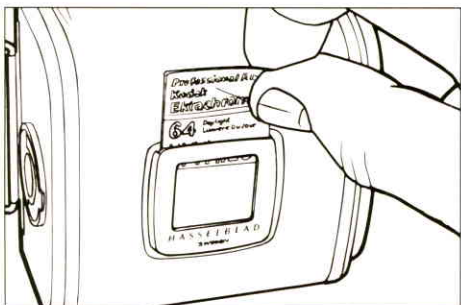

Changing the Magazine Status Indicator

To change the magazine indicator from red to white at any other frame number than 1 you fold out the film winding crank and turn it clockwise. The indicator changes after approx. 3/4 turn, but you should continue for about half a turn until the new frame number is centered in the counter window to avoid overlapping frames.

Film Tab Holder

The end tab of the film pack can be inserted in the holder on the back of the magazine as a reminder of the kind of film you have loaded into the magazine.

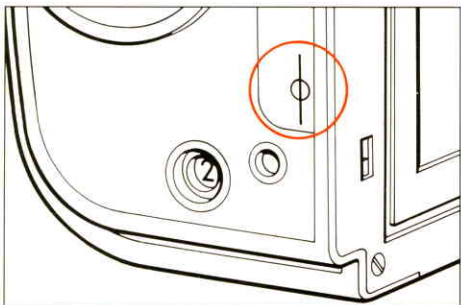

Film Plane Index

The film plane index on the right hand side of the magazine body indicates the position of the film plane to facilitate accurate determination of the film-to-subject distance, which is very important in close-up photography

Viewfinder System

Changing the Viewfinder

The film magazine or rear cover must be detached before the focusing hood or other viewfinder can be removed. The focusing hood should be folded down before being removed, to prevent it from being damaged.

Remove the hood by sliding it to the rear in its guide slots.

Slide the replacement finder into the slots and push it forward.

Attach a magazine or rear cover to the camera.

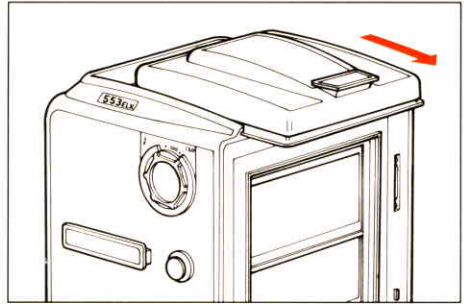

Changing the Magnifier

The complete magnifier plate in the focusing hood can easily be interchanged with other plates with correction lenses to compensate for different eyesight. Correction lenses with powers ranging from +3 to -4 diopters are available mounted in plates and marked with the correction power of the lens. The change is easily carried out by following the procedure below.

Remove the focusing hood from the camera and open it by lifting the lid firmly at the rear edge.

Bring the magnifier to the viewing position by moving the oval button in the direction of the arrow.

Push the magnifier half way back down to its folded position.

Grip the lower edge of the magnifier between thumb and forefinger (through the underside of the hood), and pull firmly.

The replacement lens is inserted by reversing the above procedure.

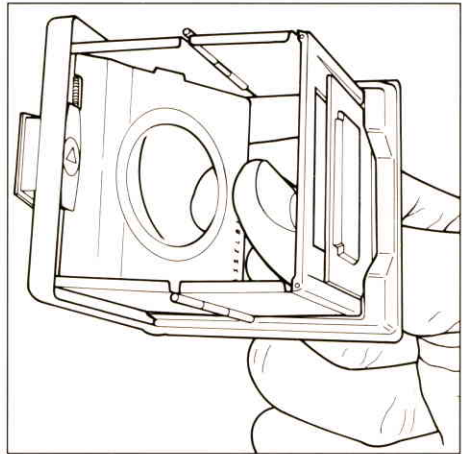

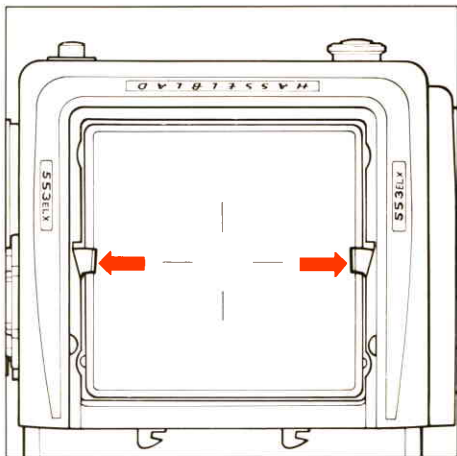

Changing the Focusing Screen

The screen is easily interchanged without the requirement of special tools:

Detach the magazine and viewfinder.

Slide the screen latches to the side. Cup your hand over the screen, and invert the camera.

The screen will now drop into your hand.

Insert the replacement screen, ensuring that the smooth flat side of the frame is uppermost, and that all four corners are seated on the support pins.

It is not necessary to return the screen latches. This is done automatically when the viewfinder is replaced.

In the Hasselblad Product Catalog you will find the entire range of focusing screens of different designs for various applications.

The 553ELX model is equipped with an Acute-Matte focusing screen which provides a considerable increase in the brightness of the focusing image when compared with the older Hasselblad focusing screens. On page 30 you will find instructions on how to adjust the PME and PME3 / PME5 Meter Prism Viewfinders to compensate for the light level differences on the different focusing screens.

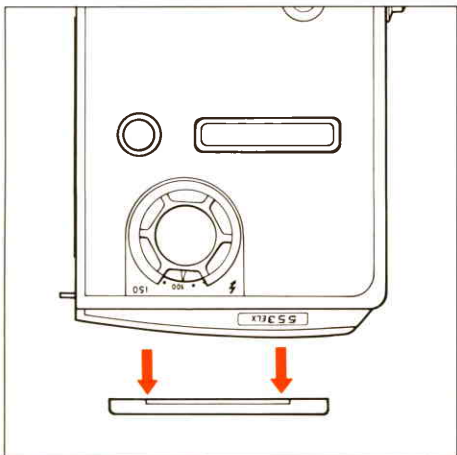

PME and PME3 / PME5 Meter Prism Viewfinder Adjustments

Since the Hasselblad Meter Prism Viewfinders measure the light level on the focusing screen they have been calibrated at the factory to give an accurate reading with one particular type of screen. If that focusing screen is replaced with another type which gives a different light level under the same ambient conditions, the meter has to be adjusted to compensate for the difference.

The PME and PME3/PME5 meter viewfinders are basically the same design but are differently adjusted from the factory. The PME3/PME5 type is adjusted to the brighter Acute-Matte screen in the 553ELX camera while the previous PME type is adjusted to the lower light level of the Ground-glass screen (Cat. No. 42161) and similar, comparable screens, such as Split image (42188), Microprism and split image (42218), or Grid and microprism (42250). The Plain glass screen (42200) is not suitable for TTL metering.

The distinction between the two viewfinder types is indicated by the designation PME3 or PME5 respectively on the rear of the viewfinder body above the eyepiece. The PME has no designation.

The ways of compensating for alternative usage of the meter viewfinders are shown in the charts on the next page.

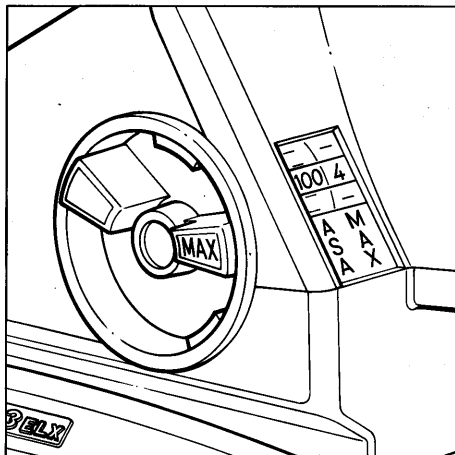
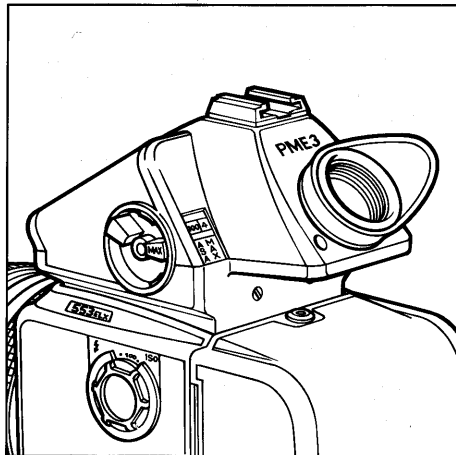

A. Acute-Matte* focusing screen, combined with:

Viewfinder model	Adjustment or action required to obtain the correct EV value
PME3/PME5	No adjustment or action required.
PME	<p><u>Reduce</u> the ASA/ISO setting to half the film speed value as indicated on the film package (e.g. to 50 for a 100 ASA film)</p> <p>or</p> <p><u>Increase</u> the MAX lens aperture setting one full step (e.g. to f2 for an f2.8 lens)</p> <p>or</p> <p><u>Reduce</u> the EV reading one full step when setting it on the lens EV scale (e.g. to EV11 instead of EV12).</p>

B. Other Hasselblad focusing screens, combined with:

Viewfinder model	Adjustment or action required to obtain a correct EV value
PME3/PME5	<p><u>Increase</u> the ASA/ISO setting to twice the film speed value as indicated on the film package (e.g. to 200 for a 100 ASA film)</p> <p>or</p> <p><u>Reduce</u> the MAX lens aperture setting one full step (e.g. to f4 for an f2.8 lens)</p> <p>or</p> <p><u>Increase</u> the EV reading one full step when setting it on the lens EV scale (e.g. to EV13 instead of EV12).</p>
PME	No adjustment or action required.

* Acute-Matte designed by MINOLTA.

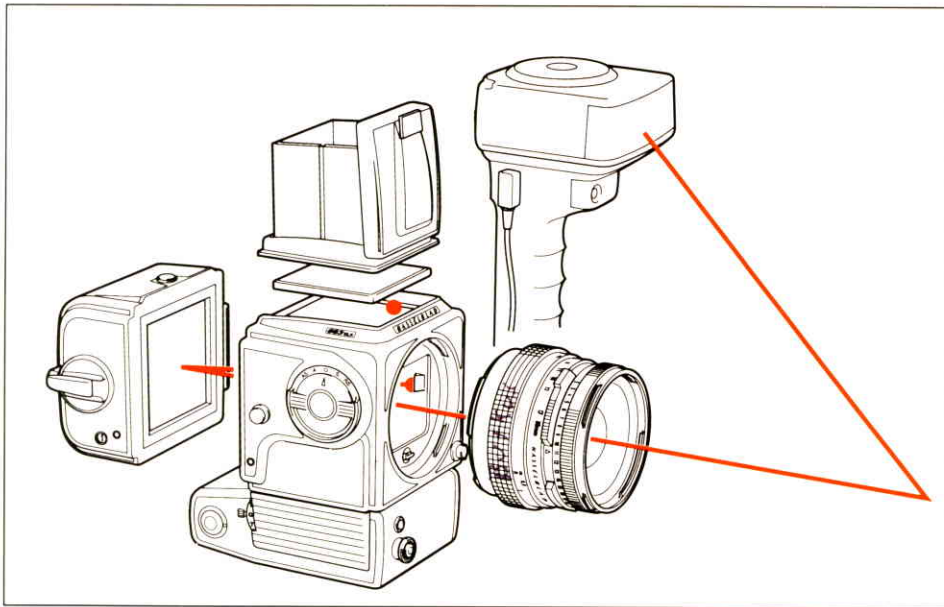

Automatic Flash Control

The camera's built-in flash sensor and electronics meter the light reflected from the central portion of the film surface, a circle with a diameter of 40 mm. The metering system is connected to a film speed selector. With the Hasselblad Proflash 4504 directly connected or any other System SCA 300 or 500 dedicated flash unit connected through the Hasselblad flash adapters SCA390 or 590 it controls the flash unit and cuts off the flash when the exposure is correct.

For connecting the Hasselblad Proflash 4504 to the 553ELX, please refer to the instruction manual for the flash unit.

Under the left hand edge of the focusing screen an indicator light shows when the flash is ready to be operated and also confirms if the flash output was sufficient to give a correct exposure.

The flash unit powers the camera's electronics and also the flash adapter, when that is used.

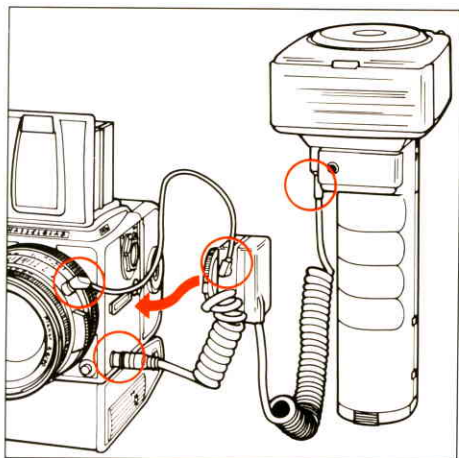

Attaching the Hasselblad Flash Adapters SCA 390 and SCA 590

For hand-held flash units, either adapter is attached as shown in the illustration above:

- the 6-pole contact from the spiral cord is connected to the camera's side socket
- the sync cord is connected from the adapter to the PC flash terminal of the lens
- the connecting cord is attached to the hand-held unit.

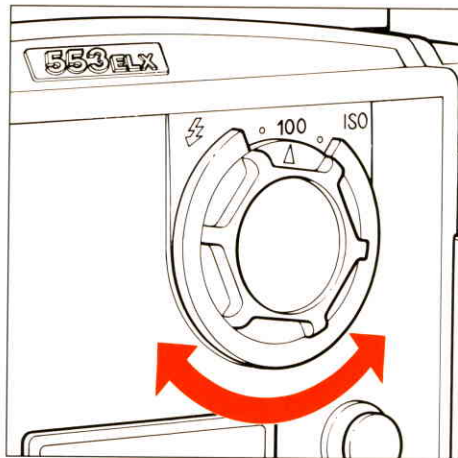

Setting the Film Speed

The film speed is set via the ISO selector. This is divided into ISO(ASA) settings from 16 - 1000. The equivalent in DIN ratings can be found using the table below. Certain films require compensation for differences in reflection. In these instances, the compensation is made by changing the film speed selector setting. The amount of compensation has to be determined by experiment.

NOTE: The SCA 300 flash unit must always be set to the "TTL" position. The SCA 500 unit must be set to the "M" (Manual) position.

ISO(ASA)	16	25	40	64	100	200	400	800											
DIN	13	14	15	16	17	18	19	20	21	22	23	24	25	26	27	28	29	30	31

Viewfinder Signal

This indicator located under the left edge of the focusing screen displays two different signals, both shown in a red glowing light. The indicator is only in operation when the camera is used with flash adapters SCA 390 or 590 and a flash unit that conforms to the corresponding System SCA 300 or 500.

Ready Signal

A steady red light indicates that the flash unit is charged and ready to be fired.

Correct Exposure Signal

A blinking red light that occurs for just over a second after exposure indicates that the flash has emitted the right amount of light for a correct exposure. After the blinking signal, the indicator returns to the ready signal when the flash unit is once again fully recharged.

Incorrect Exposure Indication

After an exposure has been carried out and the red light is unlit this indicates that the flash emitted was insufficient for correct exposure. The

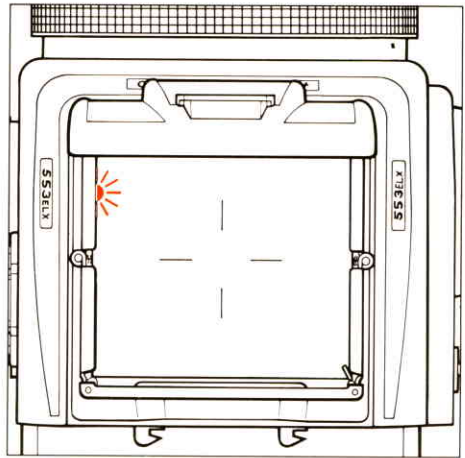

aperture must then be opened or the flash distance to the subject must be reduced. Changing to a faster film is also a possibility.

The Ready Signal will appear after a short but variable length of time depending on the condition of the flash batteries.

Please refer to your flash unit's operating instructions for more information about other functions when using automatic flash light metering that conforms to System SCA flash photography with flash sensors, or with non-automatic flash units.

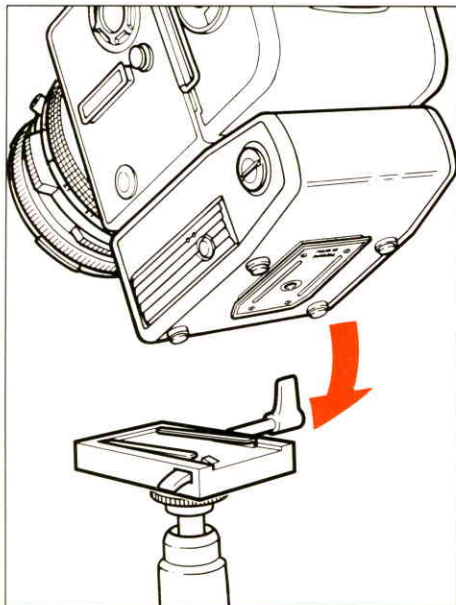

Accessories

Accessory Mounts

On the bottom of the camera body a 1/4 in. thread tripod socket is located in the centre of the quick coupling plate. The plate and socket accept flash gun brackets and the plate also fits and easily locks into the Hasselblad Tripod Quick-coupling.

If you own tripods and other accessories with 3/8 in. screws we recommend you to purchase the Tripod Quick-coupling which has both 1/4 and 3/8 in. sockets and provides an easily operated, fast and reliable tripod connection.

Should a Quick-coupling be unsuitable for your application, your Hasselblad distributor can, upon request provide a replacement 3/8 in. socket together with installation instructions.

On the left hand side of the camera body in front of the strap lug there is an accessory rail for the Flash Adapter and other accessories. The lenses accept filters and lens shades on the front bayonets.

Hasselblad Accessory Chart

The accessory chart on the opposite page indicates the wide range of accessories available within the Hasselblad System. Please refer to the Hasselblad Product Catalogue for complete information on the entire Hasselblad Camera System.

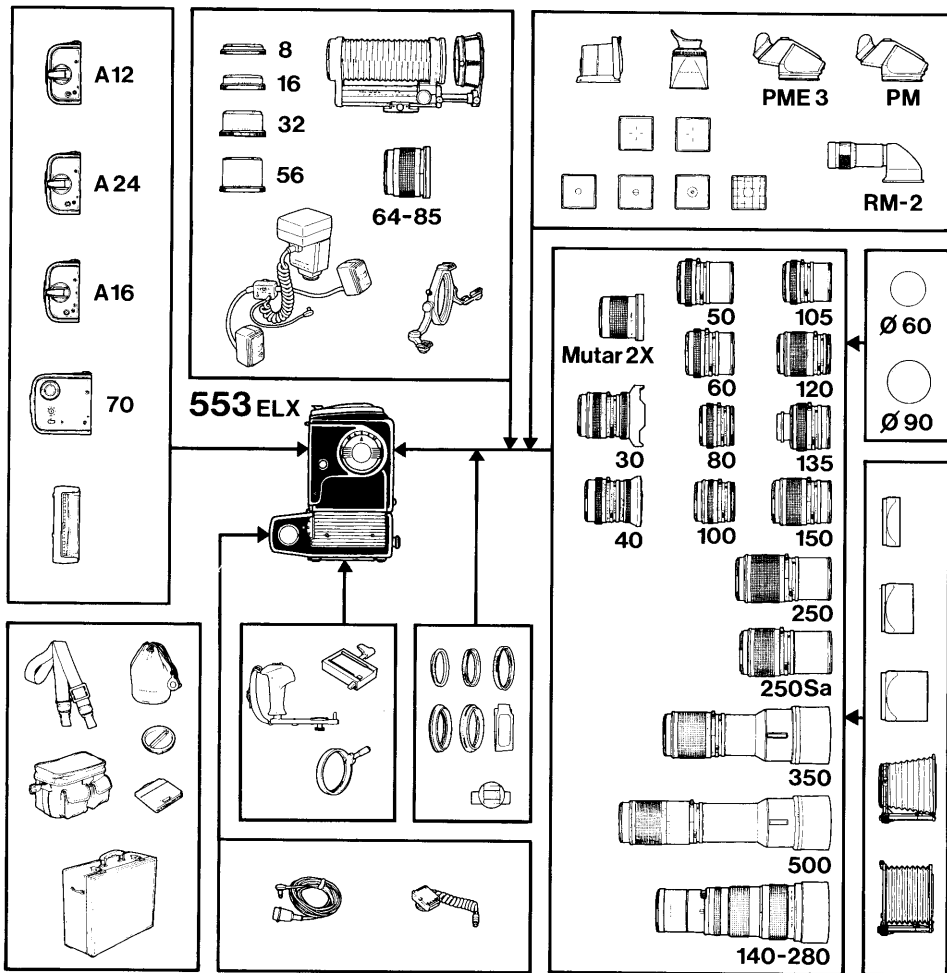

Technical Specifications and Equipment 553ELX

Camera type:	Motorized single-lens reflex camera for 6 x 6cm (2 1/4 x 2 1/4in.) film size (max.). Interchangeable lenses, film magazines, viewfinders, and focusing screens.
Design:	Integrated motor. The camera body shell and the motor housing are made of aluminium and magnesium alloys respectively and are each cast in one piece.
Viewfinders:	Folding focusing hood. The camera can accept different types of focusing screens, prism viewfinders with or without a built-in light meter, magnifying hood, or sports viewfinder.
Focusing screen:	Hasselblad Acute-Matte* focusing screen.
Film advance:	Automatic, motorized film advance and simultaneous shutter cocking. Exposure rate of approx. 1.2 frames/s. Mode selector for single and sequence exposures, with or without pre-release.
Battery/capacity:	Five size AA (LR6, AM-3) 1.5V alkaline (or 1.2V rechargeable NiCad) batteries. Up to 4000 exposures with fresh alkaline batteries.
Flash control:	TTL/OTF-measurement. ISO 16 - 1000 with flash adapters SCA 390 or SCA 590 for connection with flash units from the Systems SCA 300 or SCA 500 respectively. Measuring area within Ø40mm in the centre of the film surface.
Tripod socket:	1/4 in. socket thread and tripod plate for quick-coupling attachment.
External dimensions:	Camera body only – see opposite. Camera body with 80mm Planar CF lens and film magazine A12: 180Lx100Wx150mmH (7 1/8 x 3 15/16 x 5 15/16 in.).
Weight:	Camera body only: 1240g (2lb 12oz). The camera body with 80mm Planar CF lens and film magazine A12: 2130g (4lb 11oz).

The camera body (chrome model, product no. 10067 or black model, product no. 10221), comes with focusing hood, Acute-Matte focusing screen, fuses, carrying strap, front and rear protective covers, release plate, and FK 30 release cord.*

For comprehensive information on accessories please refer to the Hasselblad Product Catalogue.

Hasselblad reserve the right to make changes in the published specifications without prior notice.

* Acute-Matte designed by MINOLTA.

Camera Body Dimensions

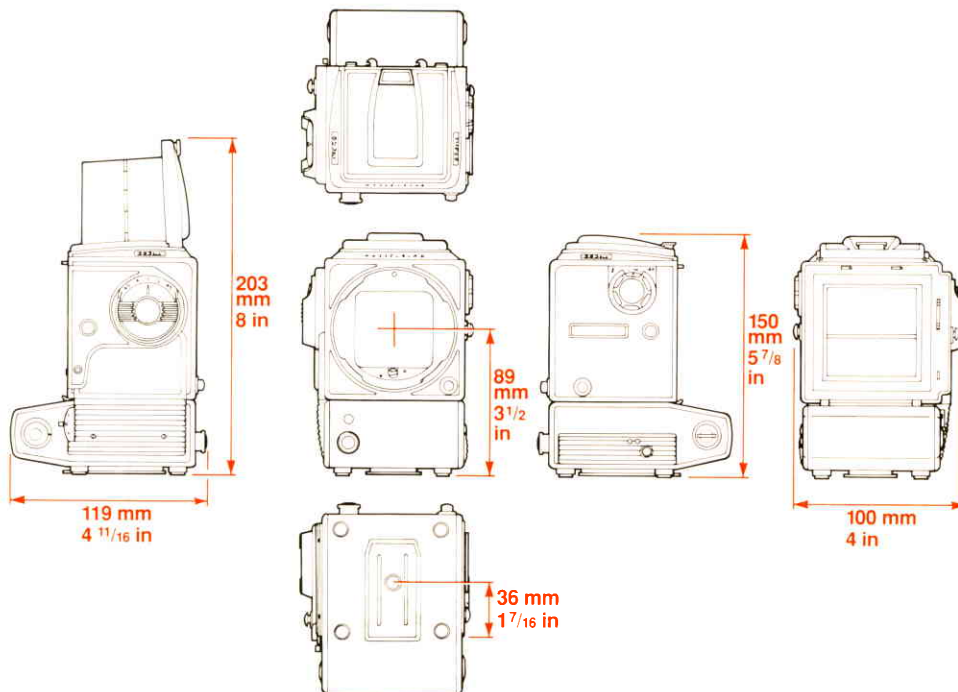

PROBLEM	POSSIBLE CAUSE	REMEDY
You cannot remove or attach the lens.	The camera is in pre-released position.	Set the mode selector in the O position and release the camera.
	The LOT lever is in the T position.	Set the lever in the O position.
	The shutter is released.	Cock the shutter (see page 8).
You cannot remove the magazine.	The magazine slide is not fully inserted.	Insert the magazine slide completely.

Circuit Diagram

Voltage: 6 - 7.5V

Batteries: Five size AA (LR6, AM-3)

Fuse: 1.6A medium slow-blow (5x20 mm)

Socket: Preh 8-6404

Exposure current (pins 1 and 3):
0.2A.

